

Magnetic Sensor IC

North Unipolar Detection High Performance Low Power Hall-Effect Sensor IC



AS1511

● General Description

Using low power CMOS process, the AS1511 is designed for low power, high performance unipolar detection hall-effect application, such as cover switch, contactless switch, solid state switch and lid close sensor etc battery operation. The hall IC integrated an on-chip hall voltage generator for magnetic sensing, a comparator that amplifiers the hall voltage, a Chopper amplifier, a Schmitt trigger to provide switching hysteresis for noise rejection, and a complementary output.

The total power consumption of AS1511 is typically less than 2.0uA at 1.8V power supply. AS1511 is designed to respond to alternating North pole. When the magnetic flux density (B) is larger than operate point (B_{OPN}), the output will be turned on (low), the output is held until the magnetic flux density (B) is lower than release point (B_{RPN}), then turn off (high).

The device is available in SOT553, SOT23-3L and DFN1216-4L Package and is rated over the -40°C to 85°C. The package is RoHS and Green compliant.

● Features

- Input Voltage Range : 1.65V to 5.0V
- Micro-power consumption ideal for battery power applications
- Uniplar Operation, easy to use as output
- Very high sensitivity hall sensor
- Low Power CMOS process technology
- Chopper stabilization amplifier stage
- Magnetic Sensitivity (typical)
B_{OPN}=-40Gauss, B_{RPN}=-25Gauss
- Good RF noise immunity
- No need pull-up resistor
- Small Solution Size
- RoHS & Green Compliant
- Small SOT553, SOT23-3L and DFN1216-4L Package
- -40°C to +85 °C Temperature Range

● Applications

- Cover switch in clam-shell cellular phones
- Cover switch in Notebook, PC/PAD
- Contact-less switch in consumer products
- Solid State Switch
- Handheld Wireless Handset Awake Switch
- Lid close sensor for battery-powered devise
- Magnet proximity sensor for reed switch replacement in low duty cycle applications
- DV, DSC, and White Goods

■ Ordering Information

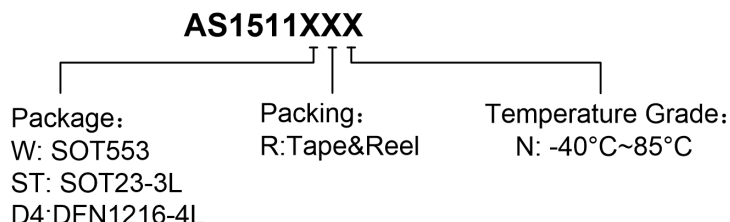

Part Number	B _{OPN} (Gauss)	B _{RPN} Gauss)	Package Type	Package Qty	Temperature	Eco Plan
AS1511WRN	-40	-25	SOT553	7-in reel 3000pcs/reel	-40~85°C	Green
AS1511D4RN	-40	-25	DFN1216-4L	7-in reel 3000pcs/reel	-40~85°C	Green
AS1511STRN	-40	-25	SOT23-3L	7-in reel 3000pcs/reel	-40~85°C	Green

■ **Marking & Pin Assignment**

SOT553:

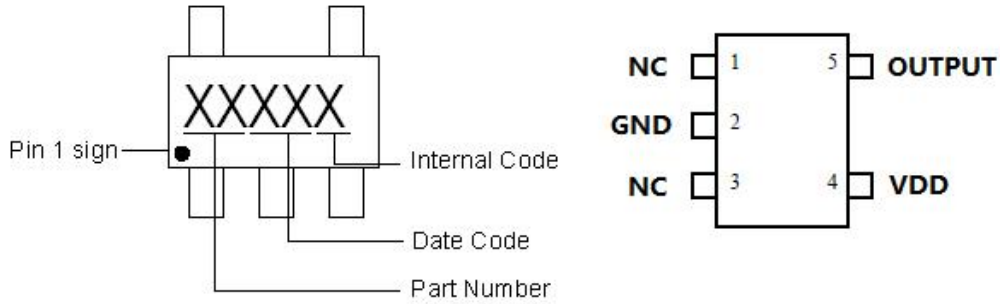

Pin Name	Pin No.	I/O	Pin Function
	SOT553		
VDD	4	P	Input Power Supply
GND	2	P	Ground
NC	1, 3	-	Not Connected
OUTPUT	5	O	Output Pin

SOT23-3L

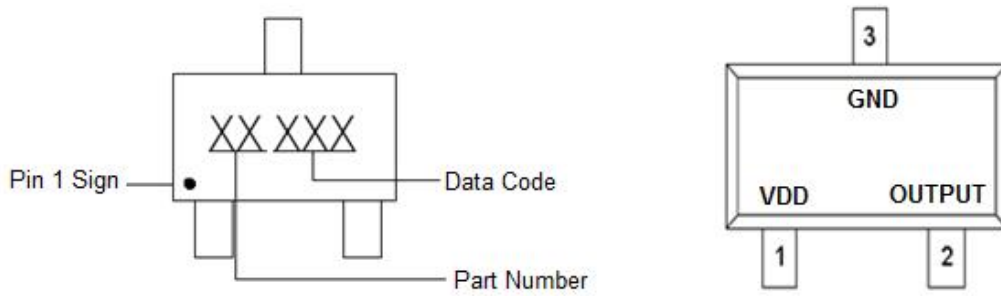

Pin Name	Pin No.	I/O	Pin Function
	TSOT23-3L		
VDD	1	P	Input Power Supply
GND	3	P	Ground
OUTPUT	2	O	Output Pin

DFN1216-4L

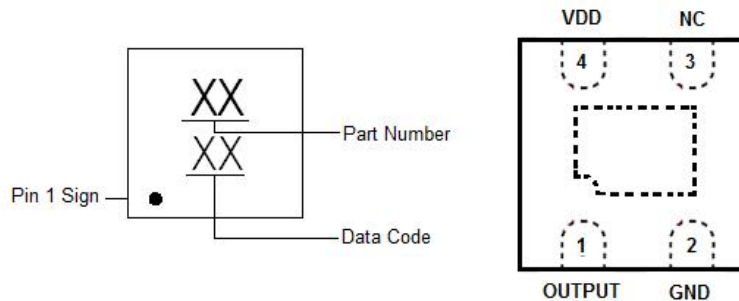

Pin Name	Pin No.	I/O	Pin Function
	DFN1216-4L		
VDD	4	P	Input Power Supply
GND	2	P	Ground
NC	3	-	Not Connected

■ **Typical Application Circuit**

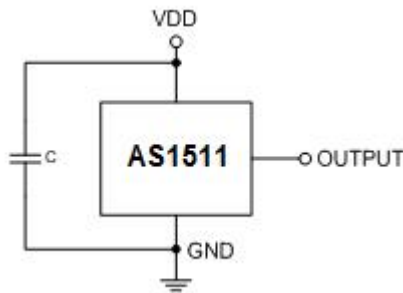

Figure 1, Typical Application Circuit of AS1511

■ **Block Diagram**

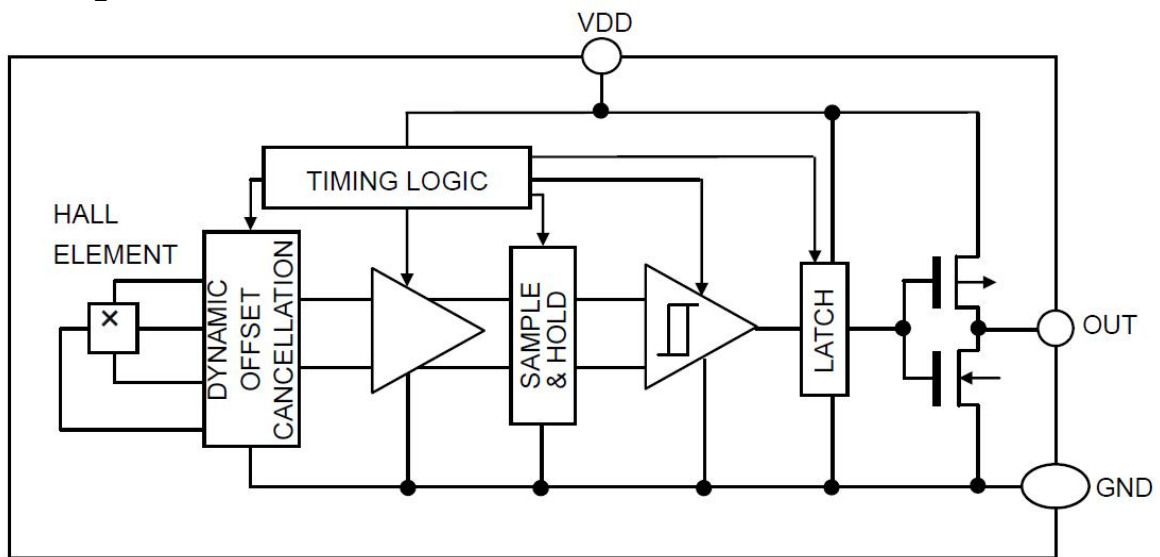

Figure 3, Block Diagram of AS1511

■ **Absolute Maximum Ratings¹** (T_A=25°C, unless otherwise noted)

Parameter	Symbol	Rating	Unit
V _{DD} Pin to GND	V _{DD}	-0.3 to 5.0	V
Output Pin to GND	V _{OUTPUT}	-0.3 to V _{DD} +0.3	V
Max. Continuous Output Current	I _{OUTMAX}	1.0	mA
Magnetic Flux Density	B	Unlimited	Gauss
Package Power Dissipation	P _D	180	mW
ESD (HBM)	ESD	8000	V
Storage Temperature Range	T _S	-55 to +150	°C
Operating Junction Temperature Range	T _{OP}	-40 to +150	°C
Maximum Soldering Temperature (at leads, 10 sec)	T _{LEAD}	300	°C

■ **Recommended Operating Conditions²**

Parameter	Symbol	Rating	Unit
V _{DD} Pin to GND	V _{DD}	1.65 to 5.0	V
Continuous Output Current	I _{OUT}	0.5	mA
Operating Temperature Range	T _{OP}	-40 to +85	°C

Note: 1: Stresses above those listed in absolute maximum ratings may cause permanent damage to the device. Functional operation at conditions other than the operating conditions specified is not implied. Only one absolute maximum rating should be applied at any one time.

2: The device is not guaranteed to function outside of its operating conditions.

■ **Electrical Characteristics**

($T_A = -40$ to $+85^\circ\text{C}$ unless otherwise noted. Typical values are at $T_A = +25^\circ\text{C}$, $V_{DD} = 1.8\text{V}$)

Symbol	Parameter	Conditions	Min.	Typ.	Max.	Unit
V_{DD}	Input Voltage		1.65	-	5.0	V
$I_{DD}(\text{EN})$	Supply Current	Chip enable, $T_A=25^\circ\text{C}$, $V_{DD}=1.8\text{V}$	-	1.5	4.0	mA
$I_{DD}(\text{EN})$		Chip enable, $T_A=-40\sim85^\circ\text{C}$, $V_{DD} = 1.65\sim5.0\text{V}$	-	2.5	6.0	mA
$I_{DD}(\text{DIS})$		Chip disable, $T_A=25^\circ\text{C}$, $V_{DD}=1.8\text{V}$	-	1.5	3.0	μA
$I_{DD}(\text{DIS})$		Chip disable, $T_A=-40\sim85^\circ\text{C}$, $V_{DD} = 1.65\sim5.0\text{V}$	-	2.0	5.0	μA
$I_{DD}(\text{AVG})$		Average supply current, $T_A = 25^\circ\text{C}$, $V_{DD} = 1.8\text{V}$	-	1.8	4.0	μA
$I_{DD}(\text{AVG})$		Average supply current, $T_A = -40\sim85^\circ\text{C}$, $V_{DD} = 1.65\sim5.0\text{V}$	-	2.5	10	μA
T_{awake}		Awake Time		-	50	100
T_{period}	Period		-	100	150	ms
D.C.	Duty Cycle		-	0.05	-	%
V_{OH}	Output Off Voltage (High side)	$I_{OUT}=+1\text{mA}$	$V_{DD}-0.3$	$V_{DD}-0.1$	$V_{DD}+0.3$	V
V_{OL}	Output On Voltage (Low side)	$I_{OUT}=-1\text{mA}$	-0.3	0.1	+0.3	V
Magnetic Para.						
B_{OPN}	Magnetic Operating Point		-	-40	-60	Gauss
B_{RPN}	Magnetic Release Point		-	-25	-	Gauss
B_{HYS}	Hysteresis Window		-	15	-	Gauss

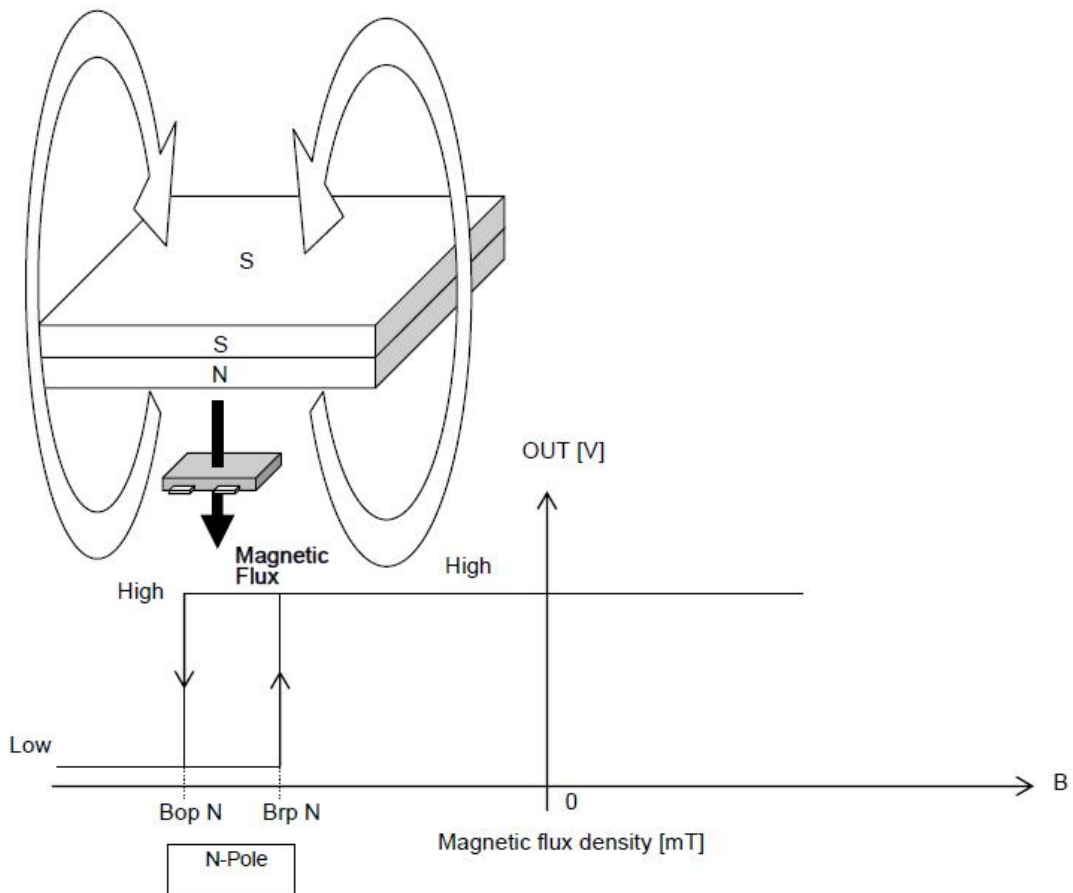
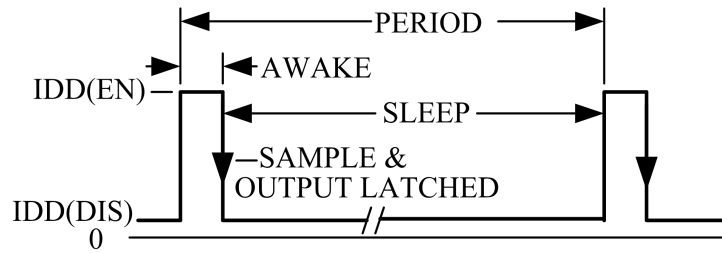

Fig 4, Magnetic Operation Characteristic of AS1511

■ **Function Description**



Micro-power Operation

Internal timing circuitry activates the sensor for 50 μ s and deactivates it for the remainder of the period (100ms). A short "awake" time allows for stabilization prior to the sensor sampling and data latching on the falling edge of the timing pulse. The output during the "sleep" time is latched in the last sampled state. The supply current is not affected by the output state.

Chopper-Stabilized Technique

The Hall element can be considered as a resistor array similar to a Wheatstone bridge. A large portion of the offset is a result of the mismatching of these resistors. These devices use a proprietary dynamic offset cancellation technique, with an internal high-frequency clock to reduce the residual offset voltage of the Hall element that is normally caused by device over-molding, temperature dependencies, and thermal stress. The chopper-stabilizing technique cancels the mismatching of the resistor circuit by changing the direction of the current flowing through the Hall plate using CMOS switches and Hall voltage measurement taps, while maintains the Hall voltage signal that is induced by the external magnetic flux. The signal is then captured by a sample-and-hold circuit and further processed using low-offset bipolar circuitry. This technique produces devices that have an extremely stable quiescent Hall output voltage, are immune to thermal stress, and have precise recoverability after temperature cycling. A relatively high sampling frequency is used for faster signal processing capability can be processed.

Magnetic Field Detection Mechanism

The Hall IC cannot detect magnetic fields that run horizontal to the package top layer. Be certain to configure the Hall IC so that the magnetic field is perpendicular to the top layer.

Operation

The output of this device switches low (turns on) when a magnetic field perpendicular to the Hall sensor exceeds the operate point B_{OPN} . After turn-on, the output is capable of sinking up to 1mA and the output voltage is $V_{OUT}(ON)$. When the magnetic field is reduced below the release point B_{RPN} , the device output switches high (turns off). The difference between the magnetic operates and release points are the hysteresis (B_{hys}) of the device. This built-in hysteresis allows clean switching of the output even in the presence of external mechanical vibration and electrical noise.

Applications:

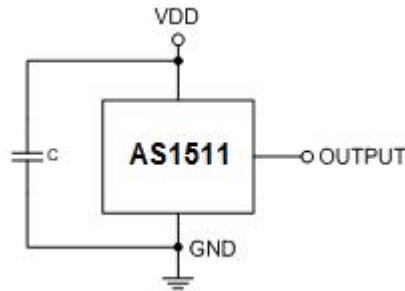

AS1511's pole-independent sensing technique allows for operation with north-pole magnet orientation, enhancing the manufacturability of the device.

C1 serves two purposes: minimizing ripples on the input voltage and enhancing immunity from RF transmission noises within close proximity. Recommended values are between 10nF and 100nF. The larger the capacitance, the better the noise immunity is for the AS1511.

It is strongly recommended that an external bypass capacitor be connected (in close proximity to the Hall sensor) between the supply and ground of the device to reduce both external noise and noise generated by the chopper-stabilization technique. This is especially true due to the relatively high impedance of battery supplies. The simplest form of magnet that will operate these devices is a bar magnet with north pole near the branded surface of the device.

Thermal Considerations

The maximum IC junction temperature should be restricted to 125°C under normal operating conditions. This restriction limits the power dissipation of the AS1511. Calculate the maximum allowable dissipation, $P_{D(max)}$, and keep the actual dissipation less than or equal to $P_{D(max)}$. The maximum-power-dissipation limit is determined using following equation:

$$P_{D(MAX)} = \frac{125^{\circ}C - T_A}{R_{\theta JA}}$$

Where, T_A is the maximum ambient temperature for the application. $R_{\theta JA}$ is the thermal resistance junction-to-ambient given in Power Dissipation Table.

■ Package Information

SOT553:

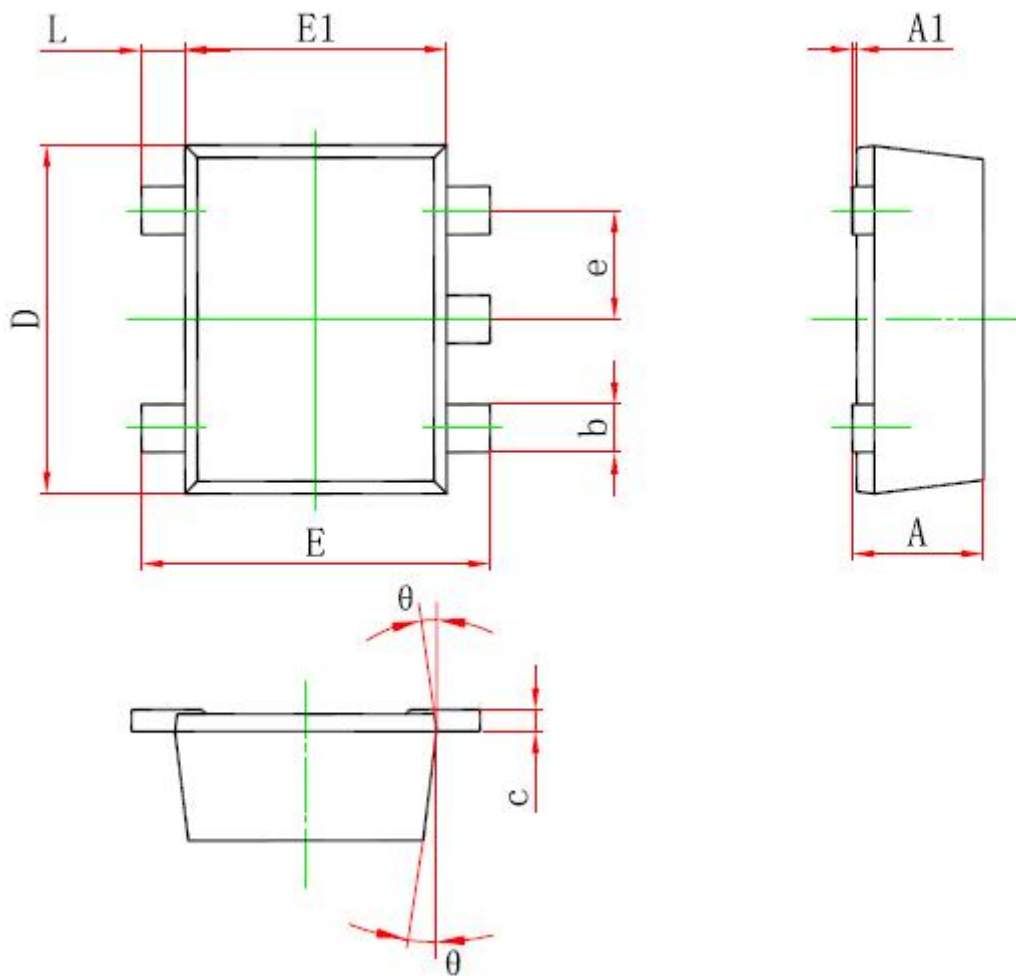

Symbol	Dimensions In Millimeters		Dimensions In Inches	
	Min.	Max.	Min.	Max.
A	0.525	0.600	0.021	0.024
A1	0.000	0.050	0.000	0.002
e	0.450	0.550	0.018	0.022
c	0.090	0.160	0.004	0.006
D	1.500	1.700	0.059	0.067
b	0.170	0.270	0.007	0.011
E1	1.100	1.300	0.043	0.051
E	1.500	1.700	0.059	0.067
θ	7° REF		7° REF	
L	0.100	0.300	0.004	0.012

SOT23-3L:

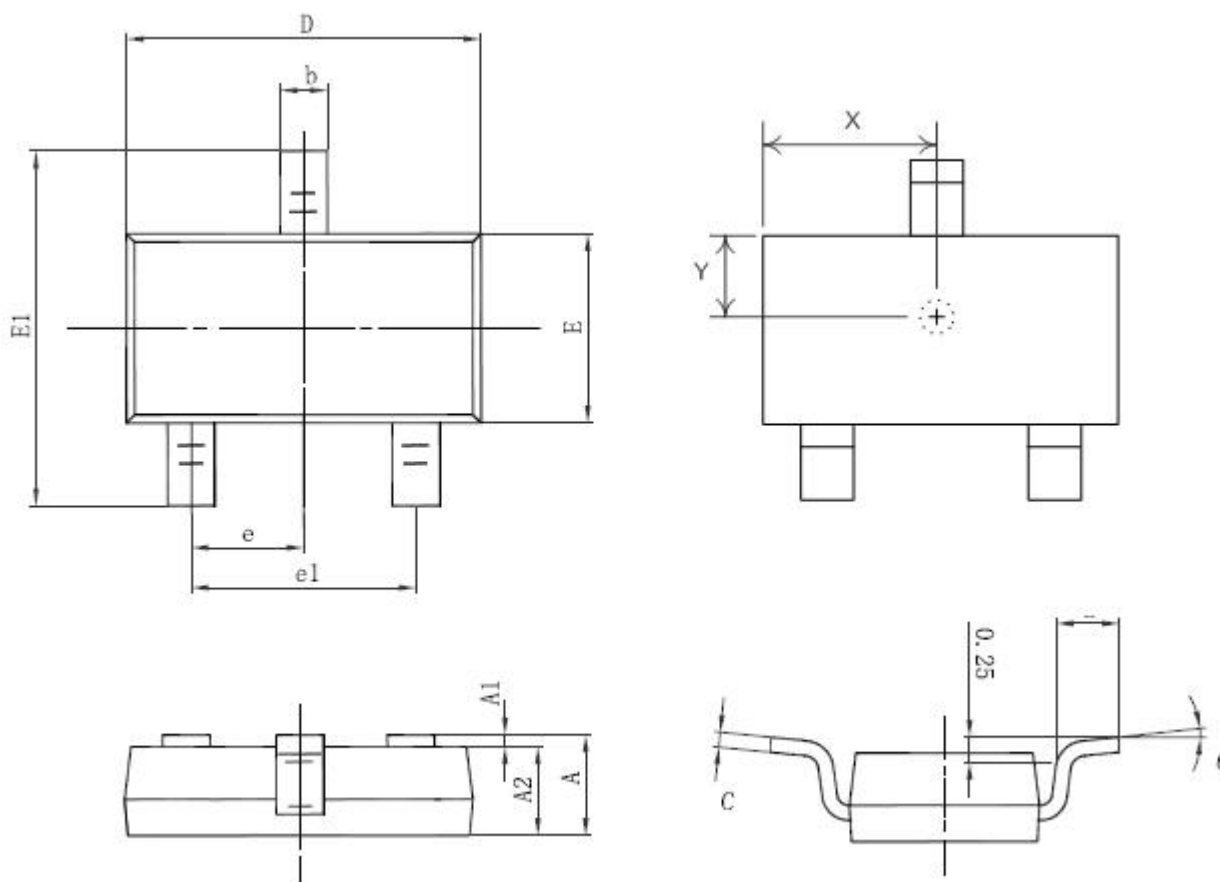

Symbol	Dimensions In Millimeters		Dimensions In Inches	
	Min.	Max.	Min.	Max.
A	1.050	1.250	0.041	0.049
A1	0.000	0.100	0.000	0.004
A2	1.050	1.150	0.041	0.045
b	0.300	0.500	0.012	0.020
c	0.100	0.200	0.004	0.008
D	2.820	3.020	0.111	0.119
E	1.500	1.700	0.059	0.067
E1	2.650	2.950	0.104	0.116
e	0.950(BSC)		0.037(BSC)	
e1	1.900(BSC)		0.075(BSC)	
L	0.300	0.600	0.012	0.024
θ	0°	8°	0°	8°
X	1.410	1.510	0.056	0.059
Y	0.800	0.850	0.031	0.033

DFN1216-4L:

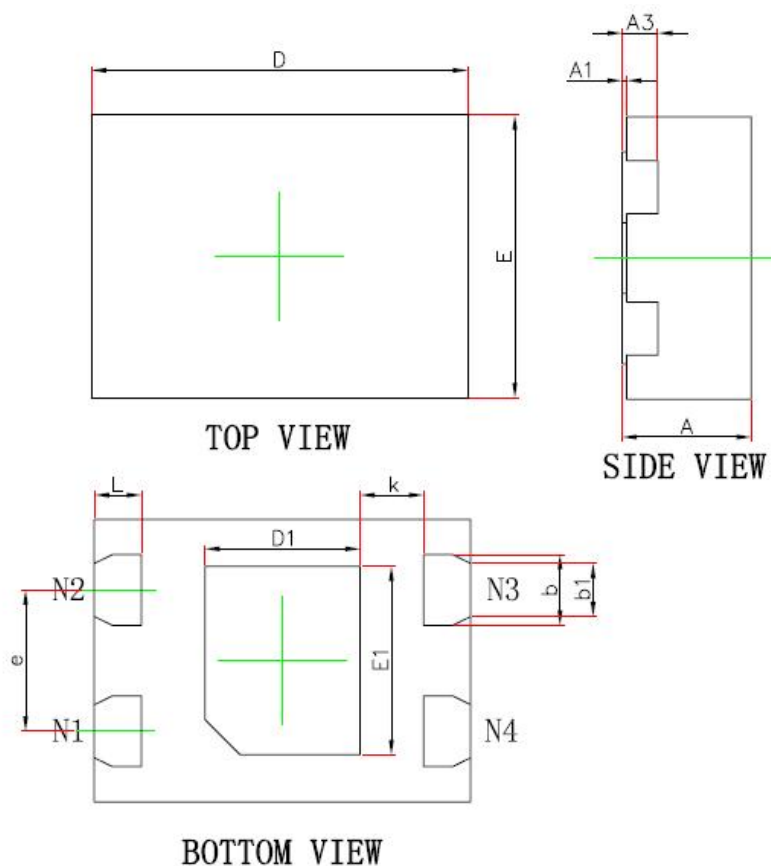

Symbol	Dimensions In Millimeters		Dimensions In Inches	
	Min.	Max.	Min.	Max.
A	0.320	0.400	0.013	0.016
A1	0.000	0.050	0.000	0.002
A3	0.102 (BSC)		0.004 (BSC)	
D	1.500	1.700	0.059	0.067
E	1.100	1.300	0.043	0.051
D1	0.440	0.640	0.017	0.025
E1	0.440	0.640	0.017	0.025
L	0.150	0.250	0.006	0.010
b	0.150	0.250	0.006	0.010
b1	0.150 (BSC)		0.006 (BSC)	
e	0.650 (BSC)		0.026 (BSC)	
k	0.330 (BSC)		0.013 (BSC)	

■ Packing Information

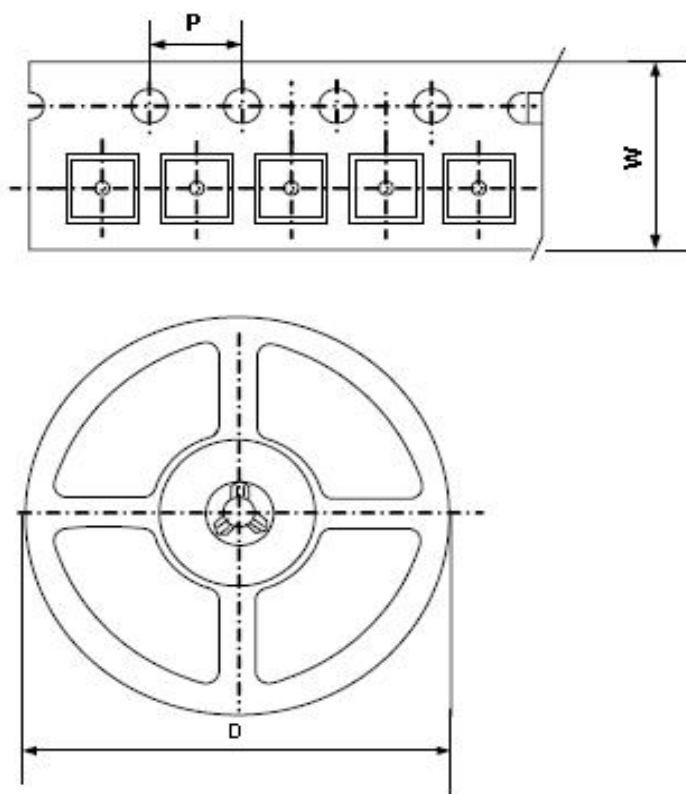

Package Type	Carrier Width(W)	Pitch(P)	Reel Size(D)	Packing Minimum
SOT553	8.0±0.1 mm	4.0±0.1 mm	180±1 mm	3000pcs
DFN1216-4L	8.0±0.1 mm	4.0±0.1 mm	180±1 mm	3000pcs
SOT23-3L	8.0±0.1 mm	4.0±0.1 mm	180±1 mm	3000pcs

Note: Carrier Tape Dimension, Reel Size and Packing Minimum